

EMPOWERING ENGINEERS TO BUILD THE FUTURE



Newark  
AN AVNET COMPANY

# EXPERT ADVICE

ISSUE 3

## SMART TECHNOLOGY SMARTER BATTERIES

ENERGY  
STORAGE  
SYSTEMS

+

DESIGN  
BETTER IOT  
BATTERY LIFE

AVOID IOT  
BATTERY PACK  
OVERDESIGN

IMPROVING  
BMS SYSTEMS

# PREFACE

Welcome to this edition of Expert Advice: Smart Technology – Smarter Batteries. In today’s rapidly evolving technological landscape, design engineers play a crucial role in shaping the future where precision meets innovation. This edition delves into the complex challenges you face in battery management.

The demand for reliable and efficient battery solutions is soaring, reshaping industries and our daily lives. As the need for robust energy storage systems grows, your expertise in optimizing battery management becomes ever more vital. Design engineers must now develop sustainable and efficient battery solutions amidst continuous technological advancements.

This edition addresses these pressing issues and explores cutting-edge innovations in your field. Discover how to manage energy storage systems easily and safely, design for improved industrial IoT battery life using emulation software, implement optimized power schemes to avoid overdesign of IoT battery packs, and enhance the reliability of battery management systems with transformers.

Each article offers practical insights, in-depth analyses, and real-world solutions tailored to your challenges. We recognize the importance of staying ahead of technological trends and aim to equip you with the knowledge needed to thrive in your profession.

We encourage you to engage thoroughly, reflect on the information, consider the underlying principles, and draw inspiration from the solutions presented. We are confident that the knowledge contained in these pages will empower you, foster innovation, and bolster your expertise in the dynamic field of battery management.



**Cliff Ortmeier**, Editor  
Email: [editor-TJ@element14.com](mailto:editor-TJ@element14.com)



# CONTENTS



ENERGY STORAGE SYSTEMS



BETTER INDUSTRIAL IOT BATTERY LIFE

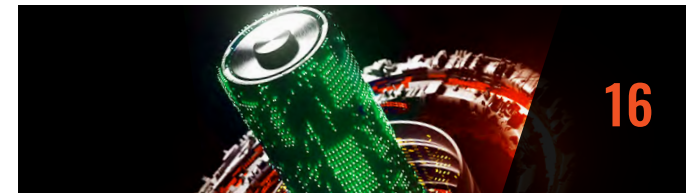

IOT BATTERY PACKS



BMS SYSTEMS WITH TRANSFORMERS

Editor-in-chief: Cliff Ortmeier,  
Managing Editor: Ankur Tomar

©Premier Farnell. All rights reserved. No portion of this publication, whether in whole or in part, can be reproduced without the express written consent of Premier Farnell. All other registered and/or unregistered trademarks displayed in this publication constitute the intellectual property of their respective holders. Errors and omissions in the printing of this magazine shall not be the responsibility of Premier Farnell. Premier Farnell reserves the right to make such corrections as may be necessary to the prices contained herein.



Scan QR code to register and to access all issues of Expert Advice



VISIT ANALOG

# ENERGY STORAGE SYSTEMS: HOW TO EASILY AND SAFELY MANAGE YOUR BATTERY PACK

Amina Joerg, Field Applications Engineer, and Paulo Roque, System Applications Engineer

Lithium-ion (Li-Ion) and other battery chemistries are not only key elements in the automotive world, but they are also predominantly used for energy storage systems (ESS).

For instance, gigafactories can produce several MWh per day of energy extracted from renewable generation. How do we account for the various burdens placed upon the energy grid over 24 hours? This can be done by using battery-based grid-supporting energy storage systems (BESS). This article discusses battery management controller solutions and their effectiveness in both the development and deployment of ESS.

## Lithium-Ion Battery Challenges

A battery management system (BMS) is needed for the use of Li-Ion cells. The BMS is indispensable because Li-Ion cells can be dangerous. If overcharged, they can undergo thermal runaway and explode. If overly discharged, chemical reactions take place within the cell that permanently affect its ability to hold charge. Both cases involve the loss of battery cells in dangerous and expensive ways. Additionally, a BMS is needed since Li-Ion cells are often stacked to form a battery pack. Charging of stacked cells is often done in series by applying a constant current source in parallel with the stack. However, this brings with it the challenge of balancing, which is the act of keeping all cells at the same state of charge (SOC). How can we charge or discharge all cells fully without overcharging or overdischarging any one individual cell in the battery stack? Balancing is one of the many critical benefits of a good BMS. The BMS's primary functions include:

- Monitoring cell parameters such as cell voltage, cell temperature, and the current flowing in and out of the cell.

- Calculating the SOC by measuring the above-mentioned parameters as well as the charge and discharge current in ampere-second (A.s) using a coulomb counter.
- Cell balancing (passive) to ensure that all cells are at the same SOC.

## Battery Management System Solutions

Analog Devices has an extensive family of BMS devices (ADBMSxxxx). The **ADBMS1818**, for instance, is ideally suited for industrial and BESS applications and can measure a battery stack of 18 cells. A microcontroller is required to operate any ADBMS IC. The microcontroller unit (MCU) communicates with the BMS, receiving the measurement data and performing computations to determine the SOC and other parameters. While most microcontrollers can communicate with a BMS, not all are suitable. A microcontroller with an extensive processing power is desirable. The data that the BMS feeds back can be large, particularly when a large cell stack is required (some stacks can reach 1500 V and are composed of up to 32 ADBMS1818s connected in a daisy chain).

In this case, the microcontroller must have large enough bandwidth to communicate with the different BMS ICs in the system while processing the results. As part of the BMS platform solution, the **MAX32626** microcontroller has two supply sources that are managed through a PowerPath™ controller. The PowerPath controller prioritizes the supply source based on board power demand (connected peripherals and processing load, etc.).

Most ADI monitoring ICs come in a stackable architecture for high voltage systems, which means that multiple analog front ends (AFEs) can be connected in a daisy chain. Therefore, one of the main characteristics of the BMS controller board, referred to as the energy storage controller unit (ESCU), is that it works with multiple AFEs at the same time.

Figure 1 illustrates a typical BMS block diagram where the ESCU is highlighted in blue. While the ESCU is not optimized for functional safety applications, the user can implement protection circuits and/or redundancies to achieve certain Safety Integrity Level (SIL) requirements.

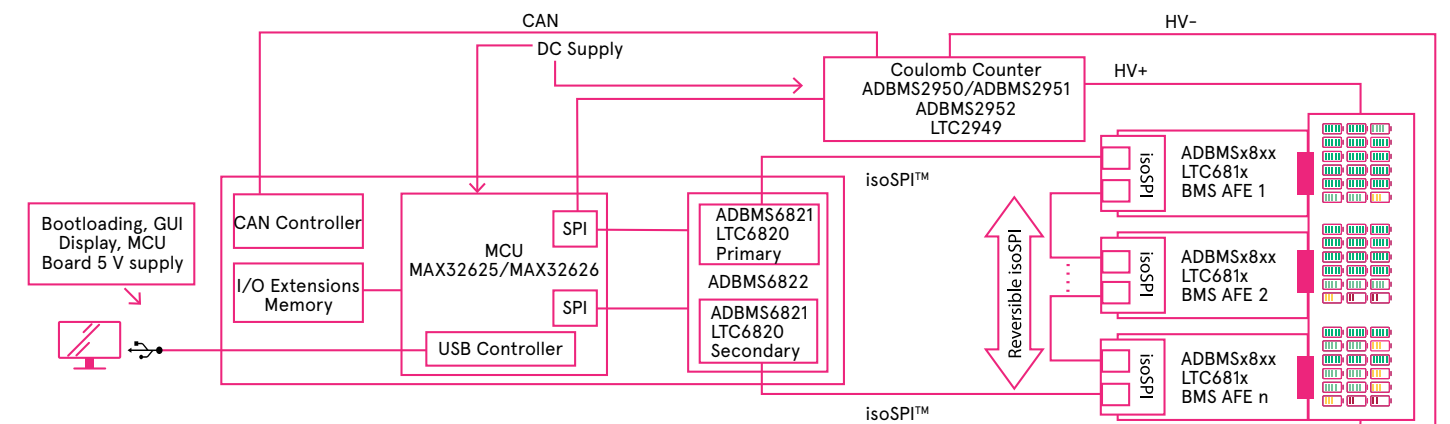

Figure 1. A simplified BMS block diagram supported with ADI BMS solutions



## BMS Controller Board Hardware and Software

### Hardware Information

ADI's ESCU interfaces with a variety of BMS devices (AFE, gas gauge, isoSPI transceiver). The highlights of the BMS controller board's hardware and components are:

#### On-board MCU

The Arm® Cortex®-M4 MAX32626 is suitable for energy storage applications. It operates at low power and excels in speed, as it has an internal oscillator running at frequencies up to 96 MHz. In low power mode, it can run at speeds as low as 4 MHz for power savings. It has excellent power management features such as a 600 nA low power mode current and an enabled real-time clock (RTC). The MAX32626 also hosts an optimal variety of peripherals including SPI, UART, I2C, 1-Wire® interface, USB 2.0, PWM engines, 10-bit ADC, and many others. A trust protection unit (TPU) with advanced security features is incorporated in this MCU.

### Interfaces

The ESCU hosts multiple interfaces: SPI, I2C, and CAN.

- isoSPI for robust and safe information transfer across a high voltage barrier.
- USB-C to power the board and flash the MCU.
- JTAG for microcontroller programming and debugging.
- Arduino connector (enables more flexibility for adding Arduino-compatible boards such as an Ethernet shield, ensor boards, or even a Proto Shield).

### isoSPI transceivers

Contains 2x **LTC6820** to achieve the isoSPI communication with the BMS ICs on a daisy chain using a single transformer. This ensures that this board is fully isolated from the BMS ICs connected to large voltage battery stacks. The presence of a dual isoSPI transceiver provides a redundant and reversible isolated communication where the host MCU alternates communication ports to monitor signal integrity (a future development of this board will include the **ADBMS6822** (dual isoSPI transceiver) for higher data rates and support of the low power cell monitoring (LPCM) function that is present in the latest ADI BMS ICs).

### Power management:

- Power can be supplied by either a DC jack or a USB connected to the PC via a USB 2.0 interface (a USB-C connector is available).
- A prioritizer circuit, using the **LTC4415**, manages and selects the supply source. It chooses between the DC jack or USB-C input based on the load at the controller and peripherals' side. For example, if an Arduino shield is connected and running, the power consumption of the board will increase beyond what USB-C can provide. The ideal diode-OR architecture of the LTC4415 will then switch over to select the DC jack as a supply source.
- The power chain provides different voltage rails (3.3 V, 2.5 V, and 5 V), which are configurable through jumpers.

### Safety and protection

The MAX32626 controls an on-board isolated gate driver, **ADuM4120**, that drives an N-FET connected to an external contactor (which sits on the battery board, for example). This has a protection function as the MCU will switch the MOSFET on and off through the ADuM4120 to open the contactors and disconnect the batteries in emergency or fault cases.

Figure 2 illustrates a high level block diagram highlighting the main elements of the ESCU.

The PCB comes in a small factor of 10 cm x 9 cm. The main interfaces are shown in Figure 3.

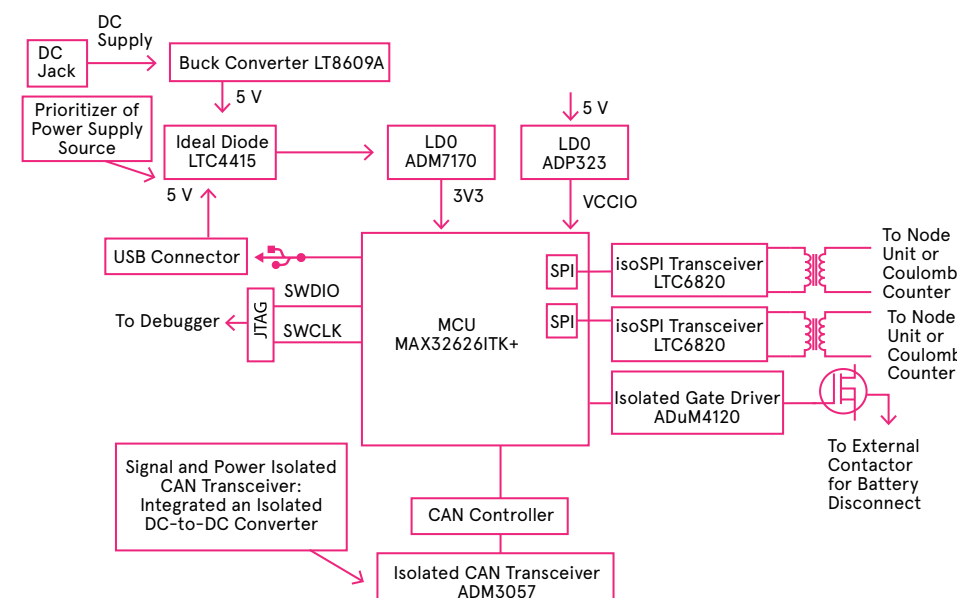

Figure 2. A detailed hardware block diagram of the ESCU

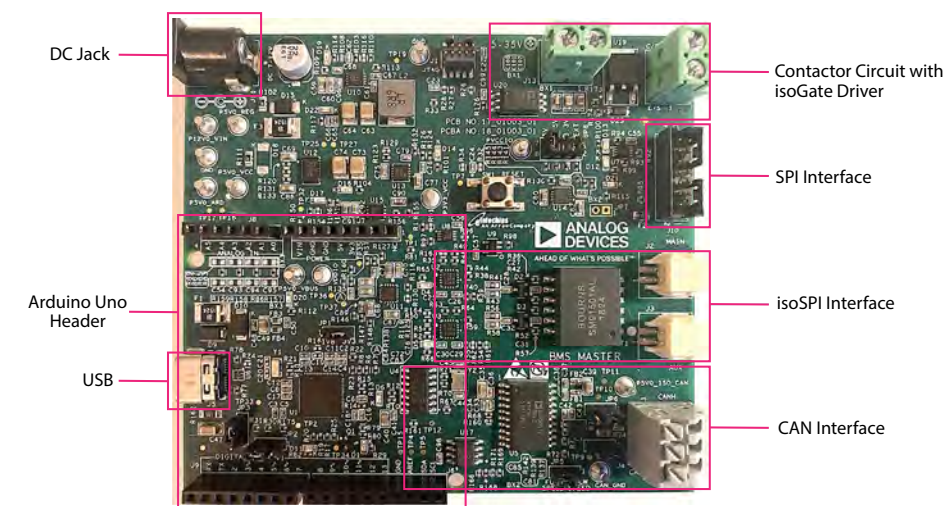

Figure 3. The top side of the ESCU

### Software Information

On the software side, ADI provides a complete solution that includes an open-source graphical user interface (GUI) that can be used to communicate with the controller board. The GUI supports up to three ADBMS devices connected to the daisy chain.

The GUI communicates with the MCU through a well-defined open-source communication protocol that can be easily extended. The protocol defines messages that are sent to the MCU over the serial port.

The messages are cyclic redundancy check (CRC)-protected to enable error detection. These messages allow the user to connect and disconnect with the MCU in an orderly fashion; set system parameters, perform measurements, enable and check for faults, and write any necessary commands to the ADBMS part.

The application code in the MCU makes use of free RTOS threads to perform parallel operations. This is useful because a measurement thread can run in parallel with a fault-checking thread so that a fault interval time can be implemented.

A software interface is provided with the BMS controller board and is written in Python. The main user sections are the following:

- System tab: This is the main landing page of the application (Figure 4). It allows the user to establish the serial PC communication, select the number of connected AFE boards, and determine the measurement interval and thresholds to be used for overvoltage and undervoltage checks. After hitting connect, the user is ready to start measurements. If both System Status lights turn green (as in Figure 4), the measurement tabs appear depending on the number of boards entered by the user.
- BMS tab/s, as illustrated in Figure 5, display the measurements processed by the ESCU to each connected AFE. The BMS tab/s contain the cell and GPIO voltages, status, and fault readings by the AFE board. The cell voltage measurement is also graphically represented and plotted in real time.
- Reference tab: The GUI includes a reference tab representing a high level block diagram of the board and schematics. The schematics and Gerber files along with the evaluation firmware, GUI, and user guide are open-source and provided by ADI.

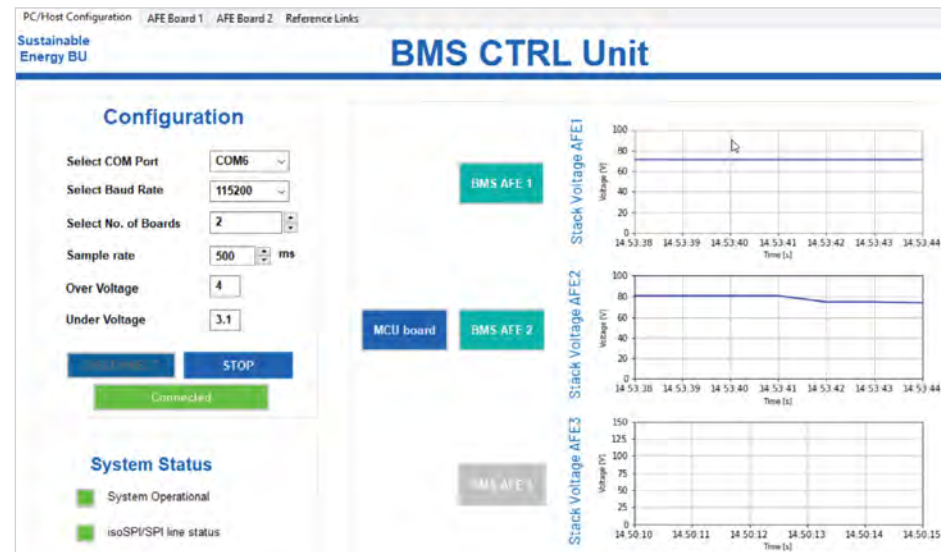

Figure 4. System tab of user application

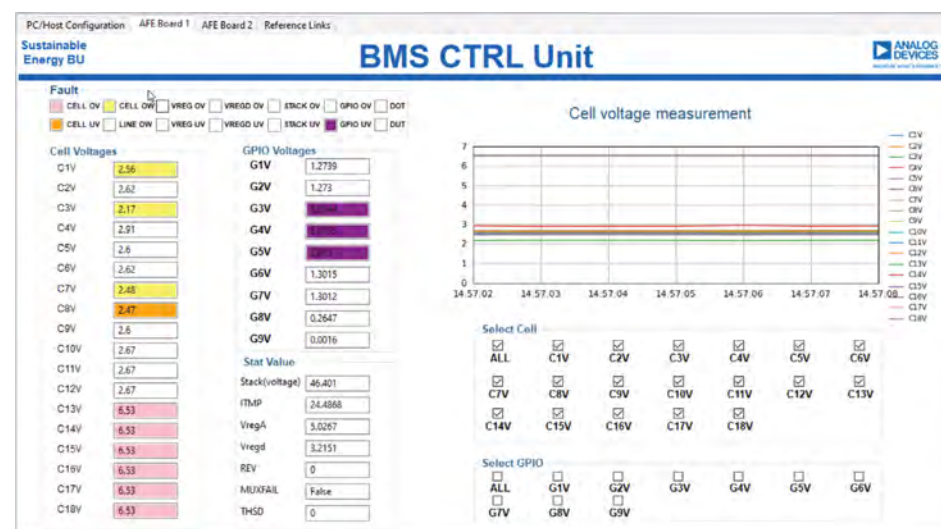

Figure 5. BMS measurement tabs

## Conclusion

In the fast-evolving energy market, there is a pressing need for BESS. The demand is urgent for a complete solution that is ready to be deployed. Support is also needed to speed up the time to market and not add unknown delays. ADI is prepared to meet that demand in full with its ESCU.

This board provides the key features required for BESS and provides a complete foundation with flexibility for further development.

With the BMS controller solution from ADI, users will be able to:

- Evaluate multiple AFEs simultaneously since this solution targets stackable and scalable architectures. No additional isoSPI transceiver board is required.
- Debug the BMS system seamlessly due to the on-board JTAG, status LEDs, and various connectors and interfaces.
- Decrease time to market by leveraging open-source hardware and software.

ADI's BMS controller board is equipped with the key features required for BESS and offers a flexible foundation that's necessary for future development. For more information on ADI's Battery Management Solutions, [visit our website](#).

## About the Author

Paulo Roque is a systems applications engineer with the Energy Storage Systems Group based in Limerick, Ireland. He has worked for Analog Devices since 2013 in various roles and products, most recently in magnetics. Paulo holds a bachelor's degree in robotics from the University of Limerick.

Amina Joerg is a field applications engineer within the Industrial Team, based in Germany. She has worked for Analog Devices since 2018 in multiple roles, most recently in the Energy Group as a system applications engineer. Amina holds a master's degree in electrical engineering from Kempten University of Applied Sciences.

## References

- Lithium-Ion Battery Energy Storage Solutions  
*Analog Devices, Inc., 2022.*
- Energy Storage Solutions  
*Analog Devices, Inc. Amina Bahri.*
- AN-2093: ADBMS1818 Slave Module Solution  
*Analog Devices, Inc., 2021.*





# HOW TO DESIGN FOR BETTER INDUSTRIAL IOT BATTERY LIFE USING EMULATION SOFTWARE

The Internet of Things (IoT) has led to an extraordinary transformation of industrial applications.



VISIT KEYSIGHT



The Internet of Things (IoT) has led to an extraordinary transformation of industrial applications. IoT enables intelligent, interconnected operations, streamlining processes, improving safety, and enhancing productivity. However, the success and utility of IoT devices largely hinge on their battery runtime.

Industrial IoT devices often operate in remote, hard-to-reach, or harsh environments, making regular battery replacement or recharging unfeasible. Therefore, long battery life is crucial for continuous, reliable data collection and system operation.

Emulation software provides rapid insight into your IoT device's current drain and lengthens the battery runtime. In addition, battery emulation and profiling software enables you to accurately predict battery life and aging effects.

This article discusses these topics in more detail and includes the following sections:

- Profiling batteries through charging / discharging to create unique battery models for emulation.
- Emulating charge states to reduce test time, improve safety, and gain insight to extend battery life.
- Automating the charging and discharging of batteries to determine capacity.
- Cycling batteries to determine capacity loss and battery life reduction.

## Profiling Batteries to Create Unique Battery Models

Profiling and characterizing batteries helps you understand the amount of energy they can store and supply without needing a physical battery. A battery model created with profiling software maps out the open circuit voltage and internal resistance versus the state of charge (SOC).

It is crucial to map out these characteristics for battery models to accurately reflect real-world performance. Figure 1 is an example of a typical plot.

Confirming the battery's performance under specific discharge conditions and operating modes is also essential. Parameters that affect battery behavior include the following:

- temperature
- load current profiles (constant /dynamic)
- operating modes, including constant current, power, and resistance

These parameters can affect battery life, so creating different battery models to match specific discharge conditions is vital.

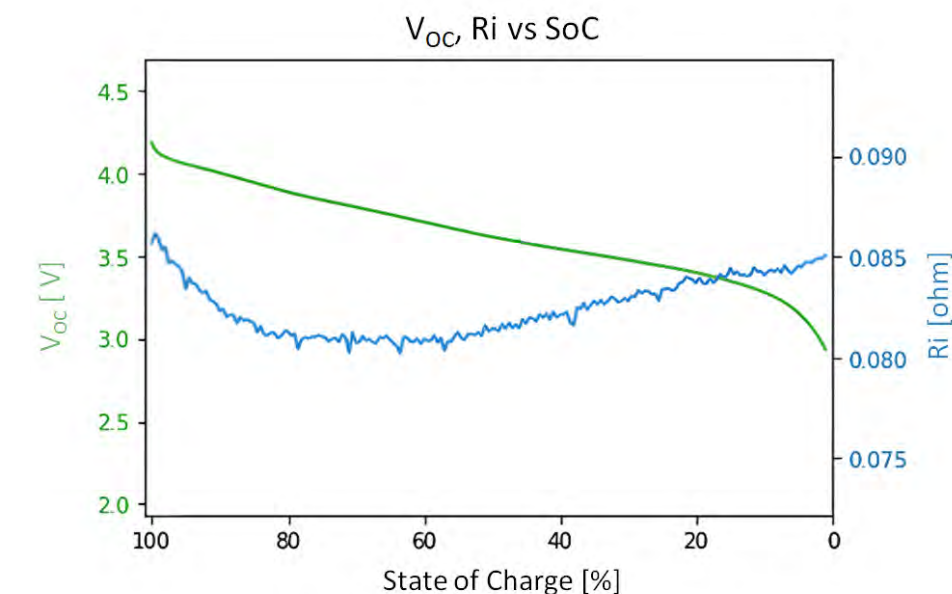

Figure 1. Battery model created with Keysight BV9210B / 11B PathWave BenchVue advanced battery test and emulation software

## Emulating Charge States to Reduce Test Time, Improve Safety, and Gain Insight to Extend Battery Life

Why use a battery emulator instead of a battery for device testing? There are several reasons:

- To create a safer test environment. It is not necessary to charge and discharge batteries when using an emulator. Charging and discharging batteries can become dangerous with repeated cycles.
- To achieve repeatable results. The characteristics of emulated batteries do not vary, while the characteristics of physical batteries can fluctuate after charging / discharging. Characteristics can also vary between batteries, even if they are the same model.
- To reduce test setup times. Instantly simulate any SOC rather than manually draining a battery to the desired level.

A battery emulator works in multiple steps. The first step is loading a battery model, comprising the plot of the battery voltage and internal resistance versus the SOC (Figure 1). You can create a battery model using battery profiling software or by receiving a profile from a battery supplier.

When you use profiling software, the model will reflect the current consumption for a specific device, which is more accurate than a battery supplier's generic profile. For example, a generic profile is not helpful if the battery supplier creates the profile based on a constant current draw when the device consumes a dynamic current. Figure 2 shows a device's current consumption profile loaded into a battery profiler.

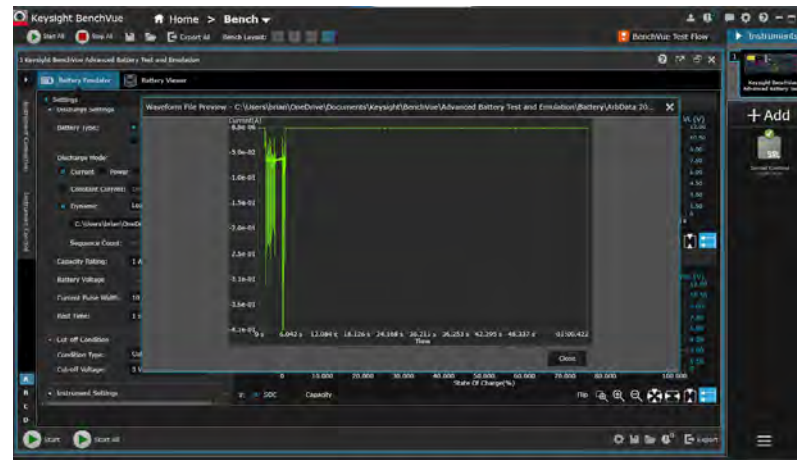

Figure 2. Device current consumption waveform loaded into Keysight BV9210B / 11B software



Figure 3. Battery emulation using BV9210B / 11B software

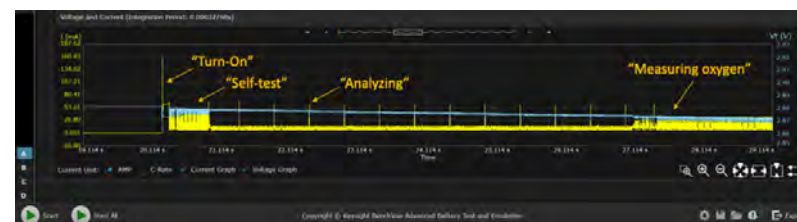

Figure 4. Current drain analysis of a pulse oximeter medical IoT device using BV9210B / 11B software

The next emulation step is to select the starting SOC and the cutoff voltage. Connect the device to the emulator and start the battery emulation. Battery emulators continuously measure the current,

charging or discharging, and dynamically calculate emulated SOC. The emulator continuously changes its output (voltage and resistance) based on the SOC to conform to the loaded battery profile.

If the emulator is discharging, the test ends when the emulator reaches the cutoff voltage.

Emulating a battery at different SOCs provides deep insight into a device's behavior. Figure 4 shows insight into a device's current drain. You can quickly assess the effect of design or software changes and optimize your design to extend battery runtime.

## Automating Charging / Discharging of Batteries to Determine Capacity

It is necessary to understand the energy a battery can store and deliver for IoT devices. Battery test and emulation software simplifies this process by automating battery charging and discharging to determine capacity.

Software must support constant current (CC) and constant voltage (CV) modes for charging batteries. As the battery reaches full capacity when charging using CC mode, the software needs to move from CC mode to a combination of CC and CV. This combination is necessary because you cannot charge a battery at the same rate when it gets close to peak voltage or capacity. You can use constant current, constant resistance, and constant power modes to discharge a battery. However, you can achieve a more accurate capacity estimate using a dynamic current waveform for battery discharge. Battery test software enables you to create a current consumption profile directly from a device.

You can then use the profile to drain the battery using software to achieve a real-world estimate. Simulating this using the actual device is difficult as you must operate it throughout the

rundown test. Therefore, it is much more practical to automate this process with software.

## Cycling Batteries to Determine Loss of Capacity and Reduction of Battery Life

Battery performance can decline significantly over a lifetime of charging and discharging. This is why it is vital to simulate battery cycling. A battery cycling software solution must support the ability to create varying charging and discharging profiles. The

software can then combine disparate sequences to simulate complex charging and discharging cycling profiles. Then you can confirm how a battery's performance degrades over time.

Emulation software solutions are ideal for this as they can enable, for example, up to 1,000 cycle operations to determine the battery's aging effect and reliability under sequence test conditions. Software must offer data-logging capabilities to store all this data.

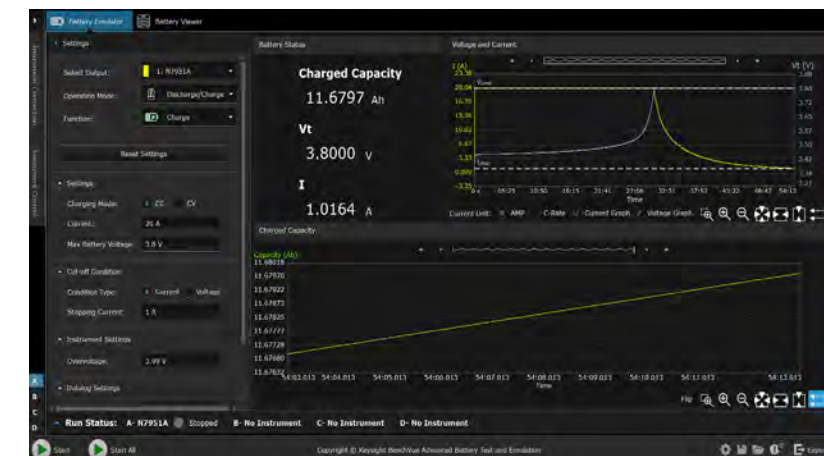

Figure 5. Visually tracking battery charging using BV9210B / 11B software



Figure 6. Battery cycling testing using BV9210B / 11B software

## Conclusion

Current drain and battery rundown testing present many challenges. The manual process of charging and discharging a battery is time-consuming, but testing your device at various charge levels is crucial as battery characteristics vary. Furthermore, battery parameters and charge levels must be identical when comparing test results. Achieving this is challenging with physical batteries. Additionally, it can be difficult to determine how long a device can last on a single charge, and often battery life claims do not match reality.

Using an emulated battery can help you overcome these difficulties. First, a battery model provides a known good reference, boosting trust in your test results. Plus, you can quickly assess the effect of design or software changes on battery life by instantly transitioning the battery's charge state. These abilities enable you to enhance your designs to achieve longer battery life and smaller size.

In addition, a software solution enables you to accurately estimate battery life by automating battery rundown using the simulated device's current drain. This method is more accurate than using constant current to drain a battery. Also, the automated process is more straightforward than manually draining a battery through device usage. For more information [visit our website](#).

## About the Author

Brian Whitaker is a product marketing engineer responsible for AC and DC power supplies and electronic loads at Keysight Technologies. He has extensive experience in various technology fields, having worked for Texas Instruments, 3M, SolarWinds, and Ping Identity before joining Keysight.



# Power Your Next Insight

Today, your products are changing the way we all work and play — wearables, electric vehicles, and beyond.

For more than 50 years, Keysight system and benchtop DC power supplies have been changing the way engineers prove their design, understand the issues and ensure product quality. On a bench or in a system, our power supplies are ready for your application, offering optimal choices in voltage, current, capability and performance.

**Test with confidence with Keysight — and power your next insight.**



[Learn More >](#)





VISIT MICROCHIP

# OPTIMIZED POWER SCHEME REFERENCE DESIGN AVOIDS OVERDESIGN OF IOT BATTERY PACKS

Modules using the narrowband NB-IoT protocol for data communications across the Internet of Things (IoT) often rely on a non-rechargeable battery pack that needs to last as long as possible without being serviced or replaced.



The lifetime and performance requirements often lead to over specification of the battery pack in such IoT systems, increasing the size and cost of the end design while reducing the overall efficiency. This optimized power scheme reference design from Microchip uses a selection of components from its portfolio to provide a more reliable, efficient and affordable solution for non-rechargeable battery pack-based NB-IoT systems.

These IoT systems remain in low power modes for 99.9% of the time, therefore the efficiency of the system largely depends on the optimization of quiescent and leakage currents. These lower power modes are called Idle, Standby, PSM (power saving mode), DRX (discontinuous reception) or eDRX (extended discontinuous reception) offering different levels of power saving options. On the other hand, NB-IoT high power mode, requires short durations of higher current pulses to achieve operations like GSM back up link e.g. 2G/GSM fall back. One of the reasons for the larger battery pack is the higher peak current requirement for the high-power mode of the NB-IoT wireless link.

The output pulse current limitation of the battery packs requires a supercapacitor (supercap) to provide these higher current pulses for the GSM back up link (TX). This supercap is often over-specified because of its intrinsic leakage current losses and performance limitations under varying environmental scenarios.

NB-IoT operates in the licensed spectrum over long distances by tapping into the 4G LTE cellular network. There are two different operating models and many different power levels that impact on the design of the power system and the specification of the battery pack. The modern narrow band IoT/LTE cat-M1 solutions are much more demanding in terms of power consumption compared to low data rate/long-range RF, such as LoRa/Sigfox and proprietary low power RF. This is true at every stage of the RF which are TX, RX and standby. When features such as GSM backup links are required, this becomes even worse as RF must be capable of providing a large amount of power, up to a peak current consumption of a few

amperes (2.3A for the module used in this design). Numbers may differ slightly from one module to the other, but this will not change the design approach described in this article.

One of the popular approaches to achieving low power NB IoT power solutions (such as water meters and gas meters) is shown in the Figure 1 below. This solution employs a battery pack charging a supercap to a voltage close to battery pack voltage (around 3.6V) followed by a linear regulator (LDO). Most applications use expensive supercaps of high capacitance value (around 10F-20F). These high value supercaps are not only costly, big and bulky, but also have a short lifetime when not overrated. There is also an intrinsic leakage current associated with the supercap that further reduces the efficiency and reliability of the design. There are also special tooling and man hours required to pre-charge these high value supercaps before connecting to battery packs to prevent over stress.

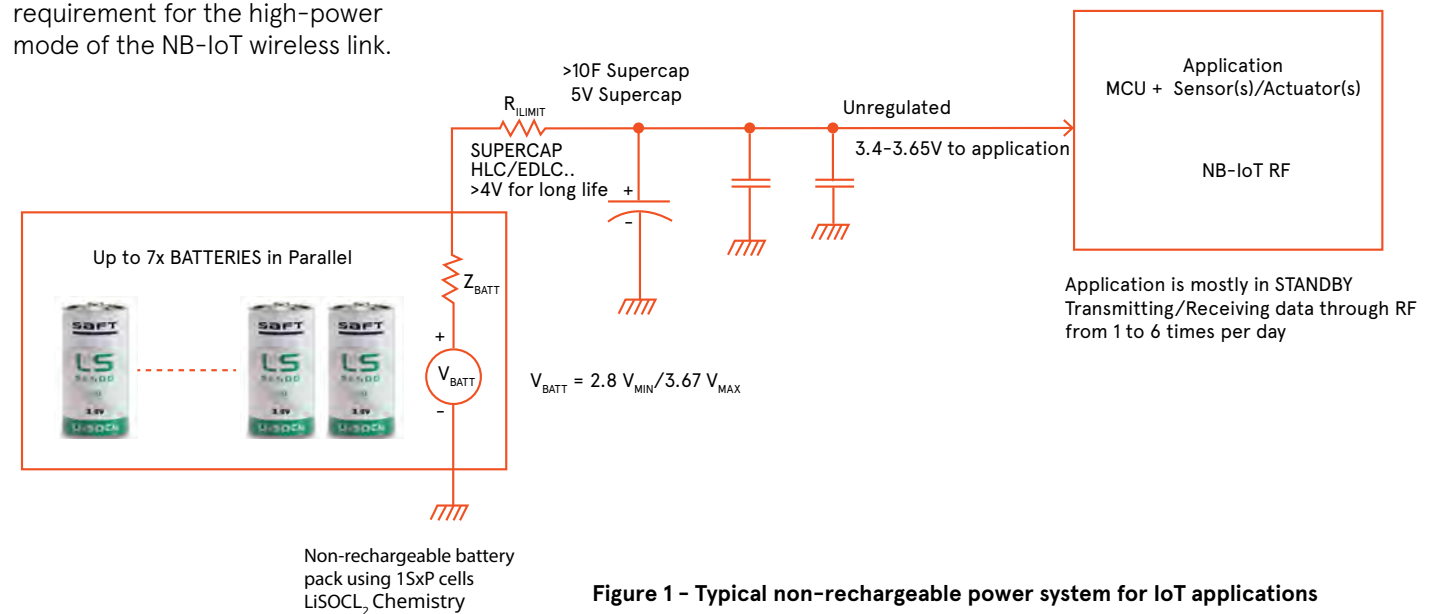

Figure 1 - Typical non-rechargeable power system for IoT applications

The choice of chemistry of the battery pack is also very important. Lithium thionyl chloride based (Li-SOCl<sub>2</sub>) primary cells offer the best compromise between cost, size and required performance, especially with ultra-low self-discharge current. These battery packs are available in different sizes (AA, AAA etc.) and the selection of any specific formfactor depends on the lifetime requirements of the design.

The Microchip optimized power scheme reference design has been developed to address the issues mentioned above. It supports different types of smart meters, from electricity and gas to water, that need to operate reliably across large areas. This drives the requirement for higher currents for longer range links, which often need a larger supercap. The proposed solution reduces the size of supercap by a factor of 20 in comparison to power schemes based on conventional linear regulator and supercap approach, allowing smaller battery packs that deliver a more efficient power scheme, a longer lifetime before replacement and higher reliability. This is achieved by using the supercap smartly during the transmission link phase of the communication link only while keeping it cutoff and discharged during the lower power intervals to avoid its leakage current power dissipation.

Other than smart metering this solution is also useful for other NB-IoT applications such as asset tracking, smart farming, smart cities waste management and parking along with smart buildings access control etc. The key to the reference design is the separate high power and low power paths, coupled with a programmable load switch. The power scheme is

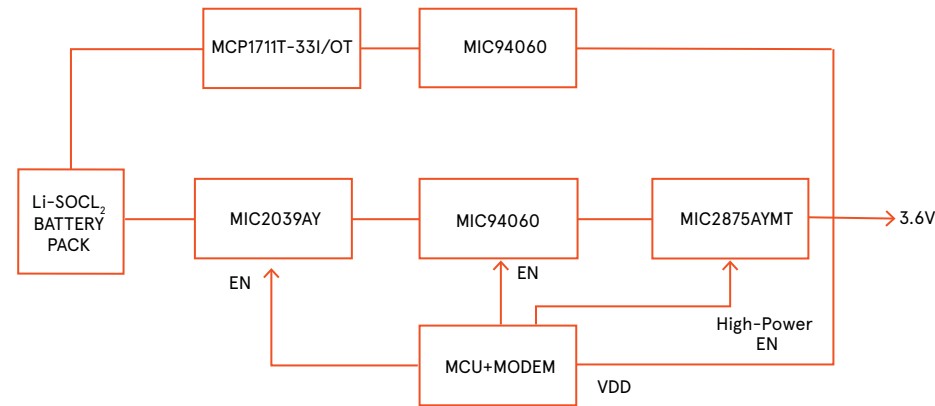

Figure 2 - High level block diagram of the Microchip proposed solution

controlled by a 16-bit PIC16F1769 microcontroller that can switch from the low-power sleep mode to the high-power mode for data transmission. In lower power modes, the high-power path is disabled, and a low quiescent current power circuit based on the MCP1711 (Low dropout (LDO) regulator) and MIC94060 (High-side power switch) is activated. This helps to extend the life of the battery pack and the overall efficiency of the system. High-power path remained disconnected during this time to optimize the overall efficiency.

As the current requirement increases from the NB IoT modem the high power high-power path is enabled. In this mode the power scheme employs a battery pack charging the supercap to a voltage close to its nominal voltage (around 3.6V). The supercap compensates for voltage drops and current source limitation of the battery pack. The design uses a low-cost controlled current source MIC2039 to charge the supercap right before the high power high power requirement of the NB IoT modem. MIC2039 acts as a linear current source to charge the supercap before

the high current is pulled from it. This mechanism ensures overload protection to avoid the battery pack stress -without exceeding its maximum pulse current specification. This controlled and predictable supercap charging process means that the charging just needs to be enabled before the application initiates tasks that need higher power.

Using this accurate current source to charge the supercap results in a deterministic charge time or charge recovery time that converges faster to the battery pack voltage than a Resistor-Capacitor (RC) charging solution. The MIC2039 also acts as a load switch by disconnecting the supercap from the battery pack when higher power is not required. MIC2039 feature an adjustable output current limit that is resistor programmable from 0.2A to 2.5A. The supercap in turn powers the MIC2875 synchronous boost converter that operates either in bypass or boost mode depending upon the charged voltage of the supercap. The boost converter regulates the output voltage of the high power high-power path.

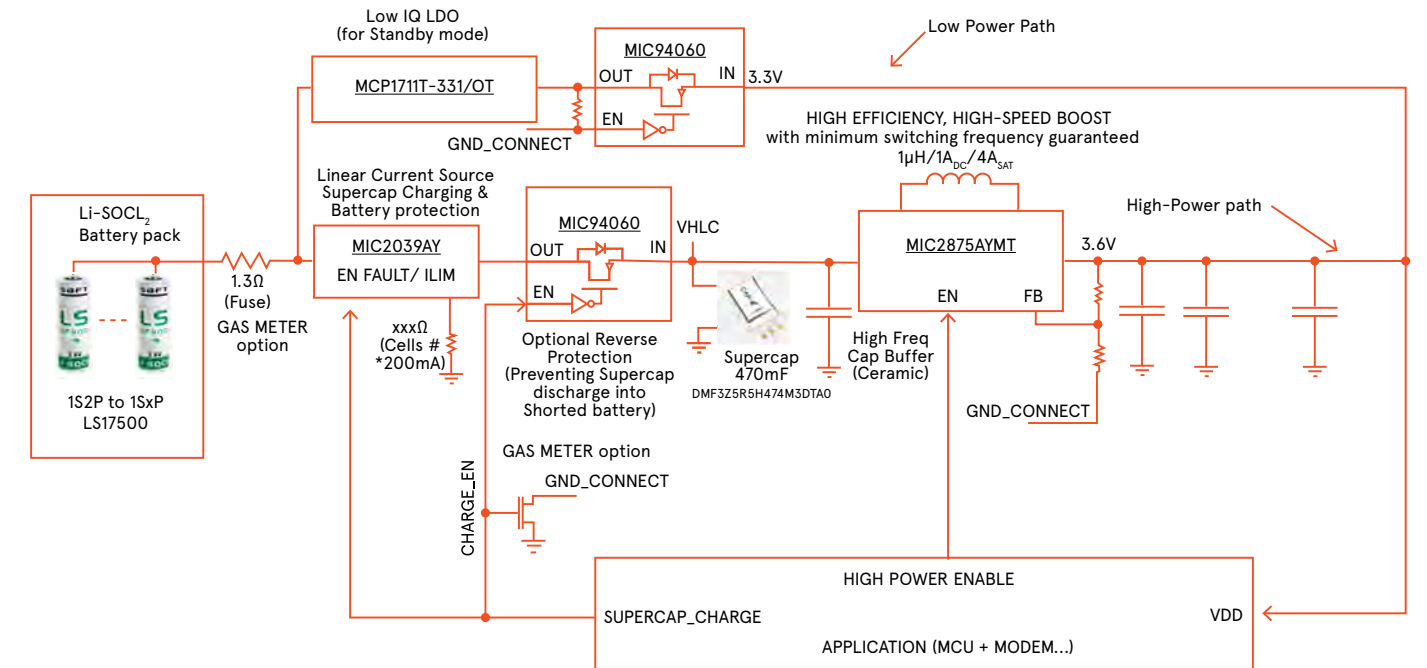

Figure 3 - Low power and high-power paths in the Microchip proposed solution

MIC2875 is a compact and highly efficient 2 MHz synchronous boost regulator with an internal 4.8A switch. It features a bidirectional load disconnect function which prevents any leakage current between the input and output when the device is disabled. The boost feature enables the design to work even when the battery is discharged below its nominal voltage. The voltage across supercap can vary from 2.5V up to 3.6V depending upon the charge state of the battery pack. To minimize switching artifacts in the audio band, the MIC2875 is designed to operate with a minimum switching frequency of 45 kHz. It also features an integrated anti-ringing switch to minimize EMI which is important for meter designs with wireless links. The microcontroller supervises these operations by maintaining timing and synchronization among different

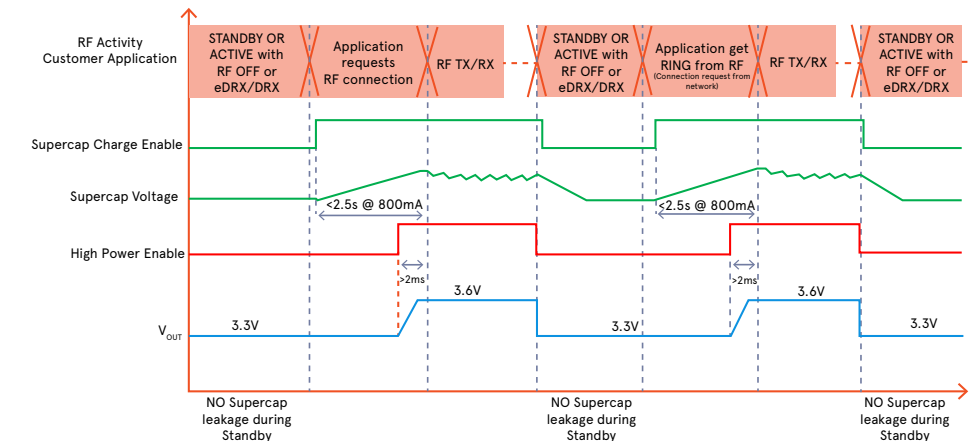

Figure 4 - Low power and high-power paths in the Microchip proposed solution

devices of high and low power paths.

The timing diagram indicates that during Standby (low power modes) the power supply provides 3.3V to the module. As the High Power Enable signal turns on, the power supply switches to high power mode and

supplies output voltage of 3.6V. To prevent the supercap leakage current loss, it is required to ramp up the supercap voltage (for an appropriate time in advance, depending on battery pack size and supercap charge current settings) before the High Power Enable signal.



## Reference Design BOM

Part Number	Product Type	Description
PIC16F1769	16 bit PIC® Microcontroller	14/20-pin, Up to 14KB, Up to 1KB RAM, Op amps, ZCD
MIC2039	Programmable 0.2A - 2.5A High Accuracy High-Side Current Limit Power Switch	ADJ, High-Side, Power Distribution Switch
MIC94060	High-side Load Switch 2A, 77mΩ	Loadswitch w/level-Shift
MCP1711	150mA Ultra-Low Iq, Capless LDO Regulator	150mA Ultra-Low Quiescent Current, Capless LDO Regulator
MIC2875	2MHz 4.8A Isw Synchronous Boost Regulator	Ultrasonic Synchronous Boost Regulator
MCP6444	450 nA, 9KHz Op Amp	MCP6444 is a 9KHz Op Amp with typical supply current of 450nA and operates from 1.4V to 6.0V. This quad Op Amp is available in SOIC and TSSOP packag
MCP6549	Open-Drain Output Sub-Microamp Comparators	600nA, 4uS, Quad Channel Open-Drain Comparators

## Conclusion

Millions of smart meters are rolling out around the world to help tackle the climate crisis. Monitoring energy and water usage accurately and regularly helps to optimise the energy networks and improve efficiency. NB-IoT is key wireless technology for providing long distance, reliable links to smart meters. However, the challenges of placing smart meters in remote locations and providing reliable data links has led to the battery packs of NB-IoT modules being over specified, or reducing the battery life, leading to higher costs for both the system and the battery packs. This validated non-rechargeable battery pack power scheme developed by Microchip combines a low cost

16bit microcontroller with a high-power path for charging a supercap for GSM back up link transmission and a low-power path for the sleep and listening modes.

This enables a supercap that can be 20 times smaller than other designs, as well as a smaller battery pack that lasts longer to offer the best compromise between cost, size and performance.

This combination of optimized battery pack selection, controlled supercap charging and smart power management improves the reliability of the non-rechargeable battery pack-based NB IoT system. It also reduces the frequency of the battery pack replacement, cutting cost for equipment suppliers and maintenance operators. For more information [visit our website.](#)

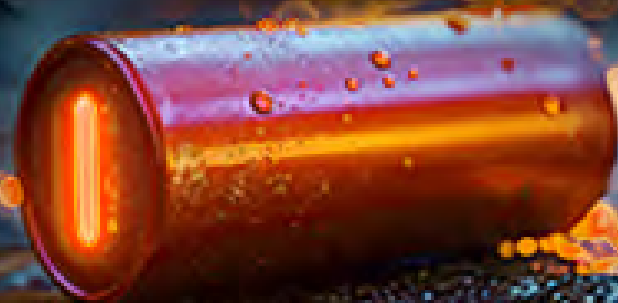

# Battery Tests Made Easy

Bidirectional DC Power Supplies work as source and sink

Power supply and regenerative electronic load: The 2U and 3U devices of the EA-PSB 10000 Series combine the functions of both devices, enabling faster and more efficient battery testing. This saves time and money during product development. As a state-of-the-art bidirectional and programmable power supply, these devices also offer users many other advantages:

- Autoranging
- High power density (up to 3 kW in 2U and 15 kW in 3U)
- Regenerative (up to 96 % returning to the grid)
- Arbitrary waveform and function generator
- Battery simulation
- Output voltage up to 2000 V
- Plug and play paralleling



[www.eapowered.com](http://www.eapowered.com)

# IMPROVING THE RELIABILITY OF BMS SYSTEMS WITH TRANSFORMERS

The conversion of electric grids to renewable energies, especially wind power and photovoltaics, which are not always available, is fueling the need for larger energy storage systems.



These require a sophisticated battery management system (BMS) for reliable operation. BMS transformers can be used to insulate the components and improve the EMC properties.

Two key pillars of the energy transition are the widespread use of wind power and photovoltaic systems. In principle, wind and sunshine are free and inexhaustible, meaning that these forms of energy can be used to generate electricity in a climate-friendly way. Unfortunately, there is one drawback: both forms of energy are not continuously available and are subject to major fluctuations. Therefore, if you don't want the lights to go out when it's dark, you need either power plant capacity or buffer storage that can at least temporarily replace the energy missing from the power grid. A case study by the Federal Environment Agency [1] and an article on the "energie-experten.org" portal [2] provide an overview of the various methods of electrical energy storage. Figure 1 shows the most common methods for storing electrical energy in terms of storage duration and capacity.

Advances in battery technology are now making large battery systems increasingly attractive as buffer storage systems. These energy storage systems then have the task of balancing out the fluctuating energy supply and changing energy demand as well as cushioning feed-in and consumption peaks.

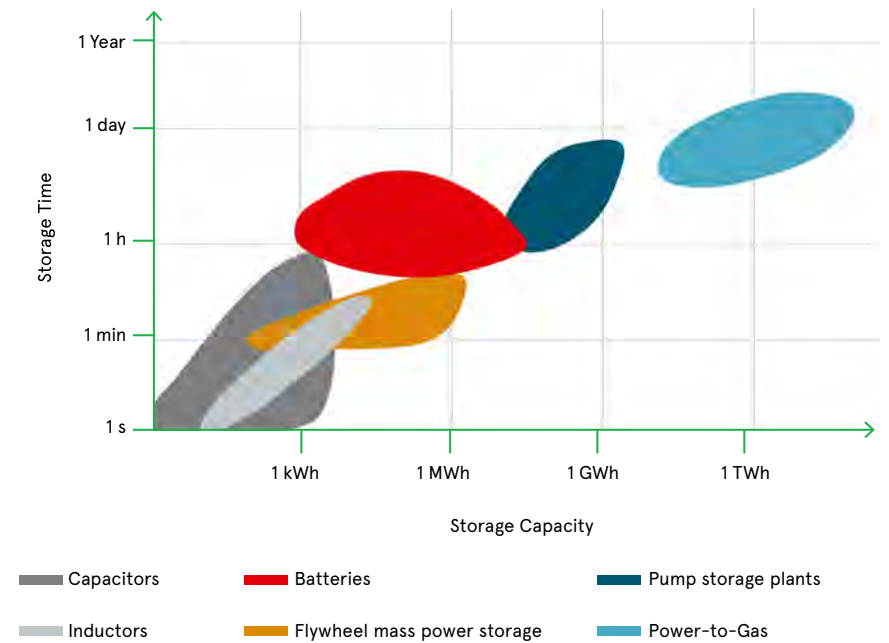

Figure 1. Method for storing electrical energy in terms of storage duration and capacity

If the company Kyon Energy, which specializes in storage technologies for the energy transition, has its way, the storage capacity for large battery storage systems in Germany will increase by a factor of 40 to 57 GWh with a total capacity of 15 GW by 2030. This is the conclusion of a study commissioned by the company together with BayWa, Eco Stor, enspired and Fluence Energy from the consultancy firm Frontier Economics [3]. The study also assumes that large-scale battery storage systems can generate €12 billion in economic added value by 2050 by shifting the availability of electricity from times of surplus to times of shortage.

At the same time, the study shows that large-scale battery storage systems have a price-reducing effect on wholesale prices and reduce the wholesale price by an average of around €1/MWh between 2030 and 2050.

If there is no possibility of using stationary battery storage instead of additional gas-fired power plants, the wholesale price could be expected to increase €4/MWh on average between 2030 and 2050.



Figure 2. The range of energy storage systems extends from small battery systems (3 to 20 kWh, left) for households to large ones (100 kWh to 5 MWh, right) for grid operators

### Which types of battery storage systems do exist?

The energy storage systems considered here typically work with electrochemical battery cells. There are various electrochemical battery cells that differ in their respective properties and areas of application. One prominent example is the widely used lithium-ion battery cells. Depending on the area of application, these systems can be differentiated according to their capacity and performance. The physical mode of operation is identical.

Although there is no direct correlation between capacity and maximum charging or discharging power, it can often be assumed in practice that the greater the capacity of a battery, the greater its maximum charging or discharging power can be.

First, it makes sense to divide batteries into three size ranges:

- Energy storage for households and small businesses, 3 to 20 kWh
- Energy storage for communities and businesses, 20 to 100 kWh
- Energy storage for electricity grid operators 100 kWh to 5 MWh

### How is a battery storage system constructed?

A battery storage system essentially consists of a battery pack with individual battery cells in which reversible electrochemical processes take place for charging and discharging. However, due to various influences such as manufacturing tolerances, ageing, etc., the individual battery cells generally do not behave exactly uniformly, but are characterized by deviations in charging and discharging behavior and

the state of charge. This is where the battery management system (BMS) comes into play, which is designed to compensate for these differences in the charging behavior and state of charge of the individual battery cells in such a way that reliable and safe operation of the battery is guaranteed. For this purpose, the BMS has a charging and monitoring unit that monitors the current, voltage and temperature of the individual battery cells and is controlled by a BMS controller (Fig. 3). The BMS controller in turn communicates with higher-level control units via bus systems and controls the power flow to and from the battery.

The BMS is basically the brain of the battery. The state of charge (SOC), the state of health (SOH) and the remaining capacity are three important metrics that are tracked and calculated by the BMS. It makes decisions based on the information it collects that affect the performance and longevity of the battery.

The BMS actively protects the battery from risks such as deep discharge, overcharging and overheating. Typical functions of a BMS:

- Protecting the battery from operating outside its safe operating range
- Monitoring the state of charge and health of the battery
- Calculation and reporting of secondary data
- Control of its environment
- Authentication and/or balancing of the battery cells

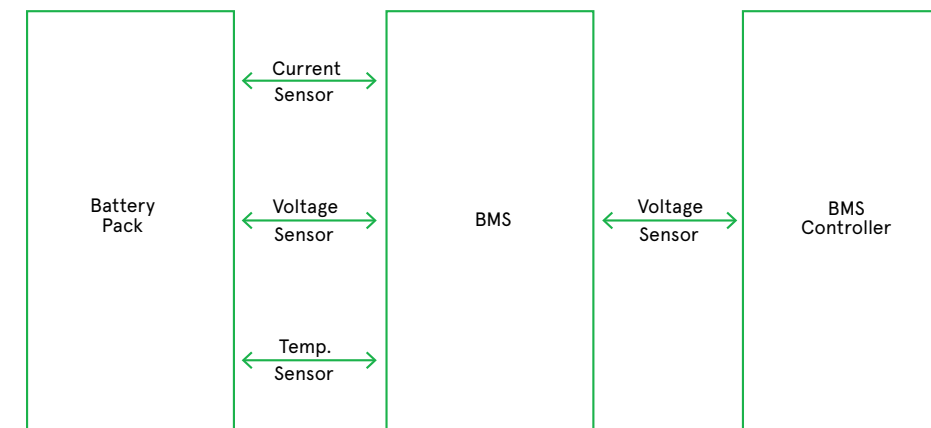

Figure 3. Structure of a battery management system. The BMS block in the center monitors the battery cells and controls charging and discharging processes

### Which role do BMS transformers play?

The individual battery cells of a battery pack are connected in series, as are the downstream BMS controllers. Voltage differences and electromagnetic interference can occur between the components or circuit boards connected in series. Transformers can be used to isolate the components between the high-voltage and low-voltage sides and suppress EMI interference. This is particularly important to ensure that no dangerous voltages are transmitted to touchable parts or the BMS. The WE-BMS transformers fulfill this function and provide BMS insulation and EMI interference suppression for safe and reliable operation. Figure 4 shows the use of WE-BMS transformers in a battery management system.

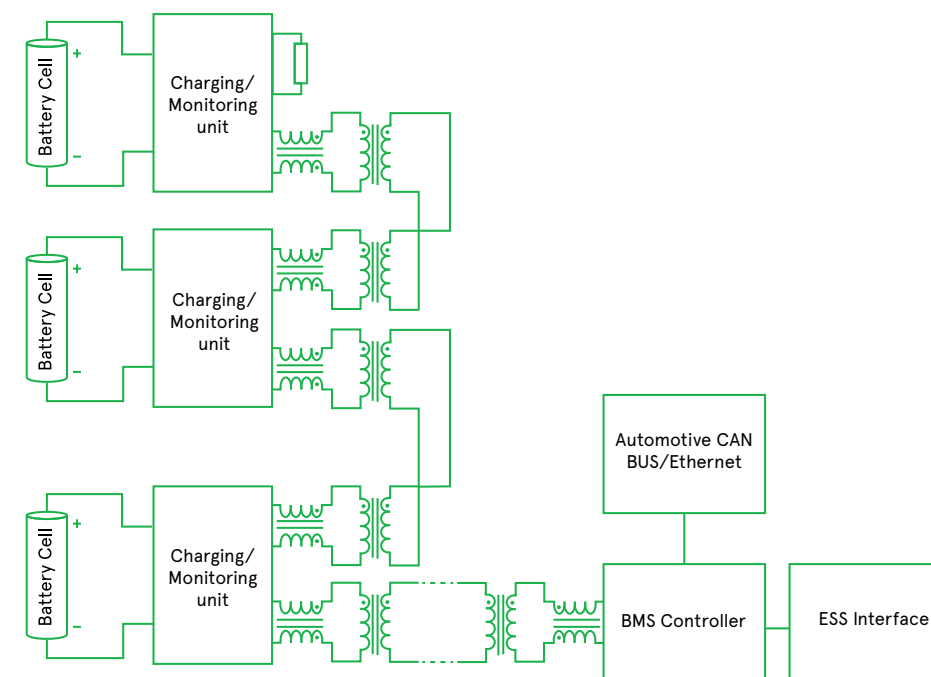

Figure 4. The WE-BMS transformers from Würth Elektronik provide galvanic isolation of the BMS and common mode chokes suppress EMI interference

## What characterizes the WE-BMS transformers?

The WE-BMS transformers from Würth Elektronik are designed for high robustness and reliability. They have reinforced insulation in accordance with IEC 60664-1 and IEC 62368-1. These standards define safety requirements for transformers and for audio/video, information and communication technology equipment. With regard to electrical energy, requirements for high-voltage tests, insulation resistances and creepage and clearance distances are described, among other things. They are equipped with a triple-insulated wire on the primary and secondary sides for the highest operating voltage. To ensure the longevity of the insulation, the WE-BMS transformers are subjected to a partial discharge test in accordance with IEC 60664-1.

The operating voltage of the latest addition to the WE-BMS transformer range has been increased from 1000 to 1500 VDC. The test voltage was also increased from 4300 to 6400 VDC. The transformers are specified for an operating temperature of -40 to +125 °C and are UL-certified in accordance with the UL standard UL 62368-1 in document E507007.

## Insulation, creepage and clearance distances

Important aspects in the design of a BMS transformer according to IEC 62368-1 are the creepage and clearance distances as well as the selection of suitable insulation for the wire. A distinction is made between functional, basic, supplementary and reinforced insulation. The differences in insulation can be seen in Functional insulation is the minimal level required for functionality.

However, this type of insulation does not prevent electric shock. Basic insulation provides the user with simple protection against electric shock. The supplementary insulation goes beyond the basic insulation and provides further protection. Reinforced insulation provides an additional layer that works in a similar way to supplementary insulation. Even if the basic insulation fails, the supplementary insulation remains effective and protects the user.

The clearance distance is the shortest distance between two conductors through air. It is important to ensure sufficient clearance distances in order to protect people and systems from the effects of electrical operating voltages. The required clearance is determined by determining the overvoltage category, the degree of contamination and the operating voltage. The minimum clearance distance can then be determined using Table 14 of the above standard.

The creepage distance is the shortest distance along the surface of an insulating material between two conductive parts. The creepage distance is determined in a similar way to the clearance distance but includes the material's comparative tracking index (CTI).

By determining the overvoltage category, the degree of contamination and the working voltage, the minimum creepage distance can be calculated using Table 17 of the standard. The difference between clearances and creepage distances is illustrated in Figure 6.

In summary these specialized transformers from Würth Elektronik improve the safety and reliability of battery management systems.

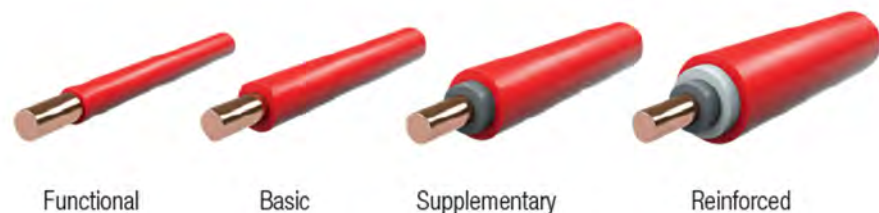

Figure 5. A distinction is made between functional, basic, supplementary and reinforced wire insulation

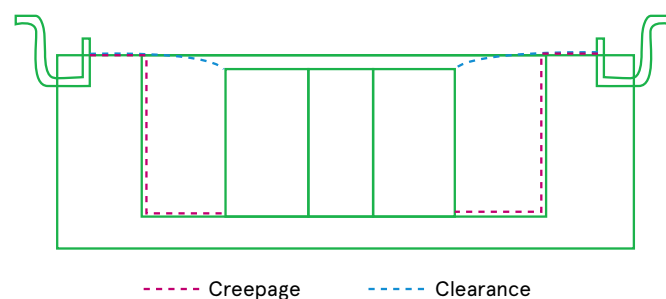

Figure 6. Creepage and clearance distances in the BMS transformer

## Conclusion

BMS transformers are crucial for enhancing the reliability and safety of battery management systems in energy storage. As renewable energy sources grow, these transformers address key issues like insulation and EMI interference suppression, ensuring safe and efficient operation. The WE-BMS transformers from Würth Elektronik meet stringent standards and improve system durability, supporting a stable and sustainable energy supply.

This advancement is vital for the success of the global energy transition. For more information [visit our website.](#)

## References

[Radgen, P.: Zukunftsmarkt Elektrische Energiespeicherung. Fallstudie des Umweltbundesamts, 2007](#)

[Energiespeicher-Technologien im Überblick](#)

[Kyon Energy zitiert Studie zu Großbatteriespeichern von Frontier Economics](#)

[BMS Transformer from Würth Elektronik](#)

## About the Authors



**Samuel Lamprecht** studied industrial engineering with a specialization in innovation and product management at the DHBW Mosbach/Campus Bad Mergentheim and graduated with a B. Eng. degree. After completing his studies in 2022, he joined Würth Elektronik eiSos as a Design Engineer and since 2024 as Junior Product Manager in the EMC & SIPI division.



**Gerhard Stelzer** studied electrical engineering and information technology at the Technical University of Munich, where he graduated with a in Dipl.-Ing. degree. He then initially worked in the development of high-rate optical communication technology at Siemens AG, from where he switched to technical journalism for the medium "Elektronik" in 1995. He has been Senior Technical Editor at Würth Elektronik eiSos since 2021.



eif505



**EXPLORE THE WORLD OF EMOBILITY  
AND POWER UP YOUR INNOVATIONS  
WITH WÜRTH ELEKTRONIK!**



WÜRTH ELEKTRONIK MORE THAN YOU EXPECT

# INDUSTRIAL EMBEDDED COMPUTERS

Enabling Next Generation of Industrial Applications

We offers the latest cutting-edge industrial embedded computers designed for use in today's most demanding industrial IoT and edge computing environments.

To give you peace of mind, our industrial computers help reduce downtime and prevent failures. Embedded computers from industry-leading suppliers are available in a variety of form factors that are ideal for space-constrained implementations and are engineered for performance and reliability.

[LEARN MORE](#)



Rugged for harsh environments



Multiple connectivity

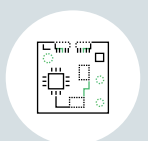

Compact form factors



Compliance and support



Long time availability



Extended I/Os



# eTECH JOURNAL

## NEWS FOR THE ELECTRONICS INDUSTRY

FREE DOWNLOAD  
**TAKE CONTROL OF YOUR POWER**



Download your free e-TechJournal edition Today!

[newark.com/e-techjournal](http://newark.com/e-techjournal)